

REVISION RECORD				
REV	ECO	DESCRIPTION	DRFT	CHKD
△		add part number	yan	10/11/06

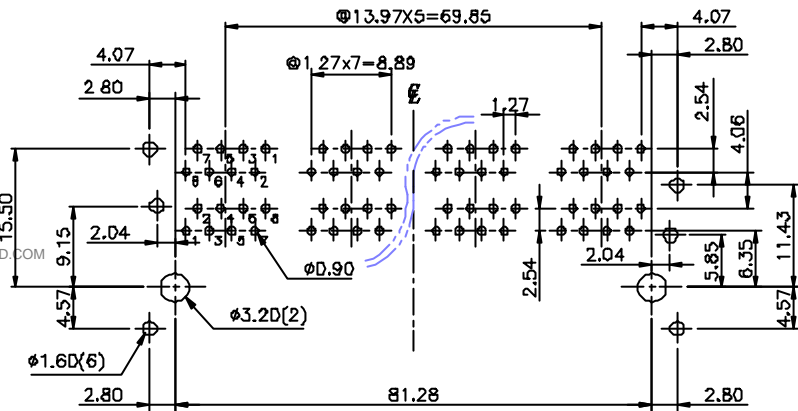
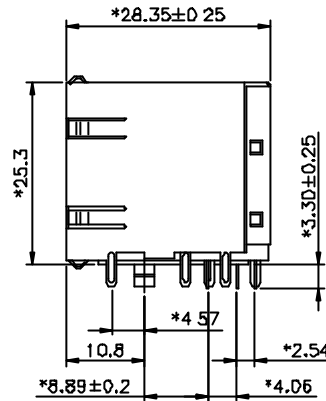
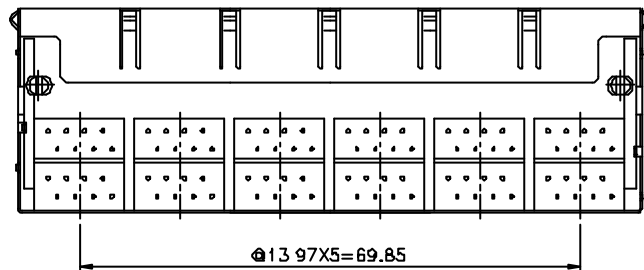
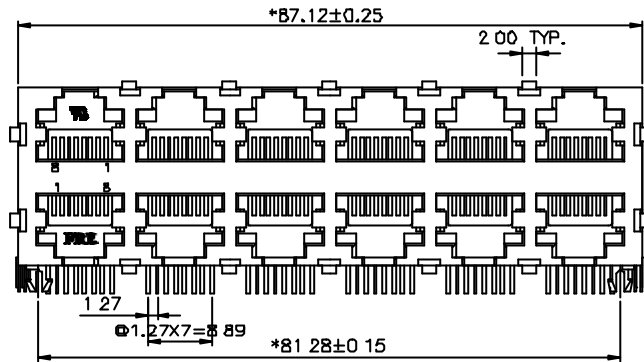

PC Board Layout
Component Side Shown

NOTES:

ELECTRICAL:

- VOLTAGE RATING : 125 VAC RMS.
- CURRENT RATING : 1.5 AMP.
- CONTACT RESISTANCE : 50 MILLIOHMS MAX.
- INSULATION RESISTANCE: 1000 MEGOHMS MIN @ 500 VDC.
- DIELECTRIC STRENGTH : 1000 VAC RMS 60Hz, 1MIN.

MECHANICAL:

- HOUSING MATERIAL : NYLON+30%.G.F UL94V-0
- CONTACT MATERIAL : PHOSPHOR BRONZE ϕ 0.46mm.
- PLATING : GOLD PLATING OVER NICKEL.
- OPERATING LIFE : 750 CYCLES MIN.
- PCB RETENTION PRE-SOLDER : 1 LB MIN.
- PCB RETENTION POST-SOLDER: 10 LBS MIN.

ENVIRONMENTAL:

- STORAGE : -40°C TO +85°C
- OPERATION: 0°C TO 70°C.
- WAVE SOLDERING TEMPERATURE: 255°C ~265°C (5~10 SECONDS).

MATES WITH MODULAR PLUG CONFORMING TO
FCC PART 68, SUBPART F.

ROHS PART NUMBER: E5908-5XEXXX-L

Shield Plating:
1- Tin
7- Nickel
Q- GOLD

Gold Thickness:
1- 3u" 2- 6u" 3- 15u"
4- 30u" 5- 50u"

1Q- FRONT PEG 4.57 A05-0130 BK W/FRE&UL LOGO
13- FRONT PEG 4.57 A05-0130 BK W/FRE&UL LOGO

昵夕 厂 J
ZWCAD 2004 刚 J
冈簿叫瑞粹WWW.ZWCAD.COM

DETAILED LISTS THIRD ANGLE PROJECTION	DIM (INCH) TOLERANCES EXCEPT AS NOTED	DFTO JANY CHKD MFD APPVL 08/08/06	DATE 7/08/06 DATE DATE DATE 10/24/05*	FULL RISE ELECTRONIC CO., LTD		
	NM 0 ±0.2 .00 ±0.10 .000 ±0.075	± ± ±	MATERIAL : QTY : FINISH : SCALE : 1.5 : 1	TITLE RJ45 STACKED GANGED JACK, 2X6		
	ANGLES ± 0.6	DO NOT SCALE DRAWING	DRAWING NO GE593A87-LA /PART NO. SEE NOTE	SIZE A3	REV 1	SHEET OF
	DO NOT SCALE DRAWING					

H
G
F
E
D
C
B
A